





OSCARO GRAVEL

OSTRO
GRAVEL



OSTRO GRAVEL

The Ostro Gravel pushes the limits of low Reynolds Number aerofoil technology to give you an edge in today's ultra fast gravel competitions. A no nonsense race bike that pulls out all of the stops to help you win.

- 45mm tire clearance.
- T47 threaded BB, with removable front Derailleur mount.
- Integrated internal hose routing, using our new 1-½" upper and lower bearings, and a round steerer tube.
- Multiple attachment points for bags, boxes, tools, and bottles.
- Mating Black Inc Hookless Thirty-Four wheels, AB02 handlebar, and 2 bolt seat post 0 or 20 mm.
-



| | | PVD | PVP |
|---------|-----------------|--------|--------|
| Ostro G | Premium package | €3.255 | €5.900 |

Premium package include (Frame, Black Inc Barstem, Seatpost, Ceramicspeed BB and headset, bartape)

Premium package + Wheels include (Frame, Black Inc Barstem, Seatpost, Ceramicspeed BB and headset + Black Inc wheels)

| | Size 49 | Size 52 | Size 54 | Size 56 | Size 58 | Size 61 |
|----------------|---------|---------|---------|---------|---------|---------|
| Stack | 515 | 535 | 555 | 580 | 605 | 625 |
| Reach | 377 | 385 | 394 | 402 | 412 | 422 |
| Rear Center | 420 | 420 | 420 | 423 | 425 | 425 |
| Front Center | 591 | 604 | 605 | 620 | 638 | 655 |
| Wheelbase | 999 | 1013 | 1014 | 1029 | 1047 | 1069 |
| BB drop | 76 | 76 | 74 | 74 | 74 | 74 |
| ST angle | 74.5 | 74 | 74 | 73.5 | 73.5 | 73.5 |
| HT angle | 71.2 | 71.3 | 72.2 | 42.3 | 72.3 | 72.3 |
| TT (effective) | 250 | 538 | 553 | 574 | 591 | 607 |
| ST | 450 | 468 | 483 | 500 | 523 | 545 |
| Fork length | 400 | 400 | 400 | 400 | 400 | 400 |
| Fork Offset | 56 | 56 | 50 | 50 | 50 | 50 |
| Trail (@683OD) | 57-62 | 57-62 | 57-61 | 57-61 | 57-61 | 57-61 |

| Model | | PVD | PVP |
|--|--|---------|----------|
| Premium Package Frame. | | | |
| OSTRO GRAVEL | | € 3.255 | € 5.990 |
| Premium Package Frame + Black Inc Wheels | | | |
| OSTRO GRAVEL + BI 34CD | | € 4.540 | € 8.140 |
| Premium complete, SRAM FORCE | | | |
| OSTRO GRAVEL | | € 5.940 | € 9.330 |
| Premium complete, SRAM FORCE + Power meter | | | |
| OSTRO GRAVEL | | € 6.075 | € 9.550 |
| Premium complete, SRAM FORCE XPLR + Power meter | | | |
| OSTRO GRAVEL | | € 5.660 | € 8.899 |
| Premium complete SRAM RED | | | |
| OSTRO GRAVEL | | € 7.250 | € 11.395 |
| Premium complete SRAM RED + Power meter | | | |
| OSTRO GRAVEL | | € 7.530 | € 11.825 |
| Premium complete SRAM RED XPLR + Power meter | | | |
| OSTRO GRAVEL | | € 6.770 | € 10.635 |

OSTRO GRAVEL

Crossover Application



The secondary intended use for this bike outside of pure gravel racing is as an “Crossover” bike, with tires ranging from 28mm-35mm. The handling geometry was carefully selected to give “road like” trail values when used with a smaller outside diameter tire. The rear center length, higher hand position fit, and slacker HTA contribute to all day comfort. The bike has been registered with the UCI for use in road competition.

OSTRO

GRAVEL

Colour Options: Naked Grunge



OSTRO **GRAVEL**

Colour Options: White Grunge



Black Inc AB02

Brand new Black Inc Aero handlebar/stem designed to maximize the free stream air flow available before the riders body fouls the air moving past the bike and rider. The gently flared design gives the rider more confidence without creating strange shifter orientations or other unexpected consequences. Brand new Black Inc Go-Pro style computer interface to support adventure use.

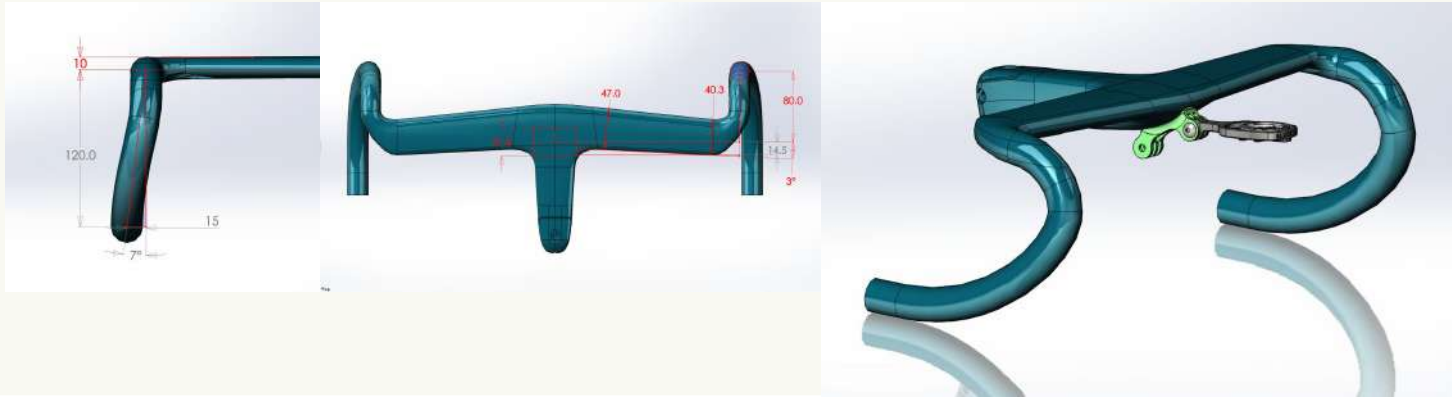

Black Inc Thirty-Four Wheelset

- The first Black Inc off-road wheel model, placing an emphasis on strength, weight, and modern features
- Intended primarily for gravel use, but also tailored for use as an on-road wheel with a 30mm or larger tire
- Modern Hookless rim design combined with classic road pedigree like custom CeramicSpeed bearings



Black Inc Thirty-Four Wheelset

PVD **PVP**

€1.413 €2.601,50



FACTORBIKES.COM